

**ROLLER SPREADER
KEY POINTS**

- 6 to 10 Gate spreaders
- Manual or wireless control
- Unit width to suit bins
- Easy removable design
- componentry
- Hydraulic or Electric drive options
- Quality powder coat finish
- Fitting and commissioning services available

Things to consider;

Number of gates?
Roller width?
Bin dimensions?
Hydraulics?
Electrical?
Pneumatics?

Our professional and friendly staff can assist you with all these and advise on how best to fit and commission for you so you can be ready for site.



Roller spreaders are an essential component in efficient and even chip coating on asphalt roads and are a major investment for most roading companies asset lists. Many look alike but performance and returns can vary significantly. For the last 40 years we have been listening to and developing these professional products for NZ Operators and NZ Owners into what works the best for our demanding situations.



Our passion in innovation has allowed us to develop units to ensure trouble free operation. Our latest designs include:

- Jam free gate designs
- Increased pneumatic ram sizes for durability.
- Precision machined rollers to provide that even “waterfall of chip flow” including when using super fine chip
- Removable roller end stone protection guides



ROLLER SPREADER

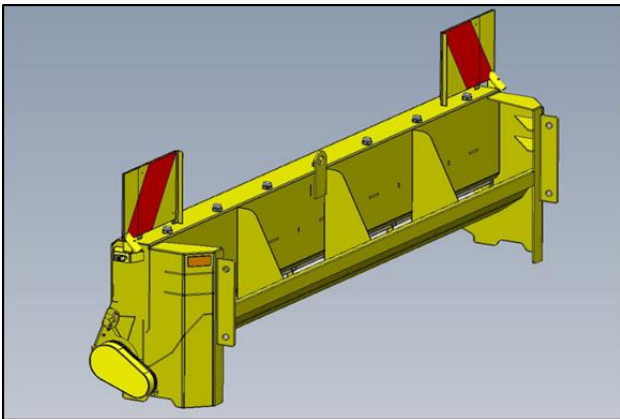

- Quality waterproof electronics & quality pneumatics and hydraulics
- Upgraded 13 Pin Trailer Plugs to future proof electrical requirements
- LED Gate indicator lights which show that a gate is actually open.
- Upgraded high quality powder coated finish
LED indicator and work lights



5 Belfast Place,
Frankton,
Hamilton

Phone: +64 7 8477583

Email: admin@cookandgalloway.co.nz



Vacuum tankers, Chip Spreaders, Cement Spreaders, Hot Boxes, Transport work, Steel alloy and stainless fabrication, Water pressure vessels, Expanded metal mesh, Trailer manufacture, Civil steel work, Structural steel, Design and build, Rolling, Fitting, Profiling, Machining, Finishing. Your complete engineering company!